



# HIGH PRECISION CNC PROFILE GRINDING MACHINE

**H** SERIES (HYDRAULIC)

**B** SERIES (BALLSCREW)

**LM** SERIES (LINEAR MOTOR)



**JOEN LIH MACHINERY CO., LTD.**

No. 240-1, Sec. 1, Tafeng Rd., Tantzai Dist.,

Taichung City 427, Taiwan

TEL: +886-4-2534-9475

FAX: +886-4-2533-9001

E-mail: grinder@joenlih.com.tw

[www.joenlih.com.tw](http://www.joenlih.com.tw)



JL-2023-02-1000C



**SADDLE TYPE**

# HIGH PRECISION CNC PROFILE GRINDING MACHINE

## ▼ H SERIES (HYDRAULIC)

- ◎ JL-52CNC-H
- ◎ JL-2550CNC-H
- ◎ JL-63CNC-H
- ◎ JL-4080CNC-H

## ▼ B SERIES (BALLSCREW)

- ◎ JL-52CNC-B
- ◎ JL-2550CNC-B
- ◎ JL-63CNC-B

- ◎ JL-4080CNC-B
- JL-4080CNC -340
- JL-4080CNC -341
- JL-4080CNC -344

## ▼ LM SERIES (LINEAR MOTOR)

- ◎ JL-52CNC-LM

### » H SERIES (HYDRAULIC)



▲ JL-52CNC-H



▲ JL-63CNC-H



▲ JL-4080CNC-H

### » B SERIES (BALLSCREW)



▲ JL-52CNC-B



▲ JL-2550CNC-B



▲ JL-63CNC-B



▲ JL-4080CNC-340  
Creep Feed Grinding



▲ JL-4080CNC-341  
Longwise Grinding



▲ JL-4080CNC-344  
Grinding Two Surfaces Of Carriage At One Time (Square Surfaces)

### » LM SERIES (LINEAR MOTOR)



▲ JL-52CNC-LM

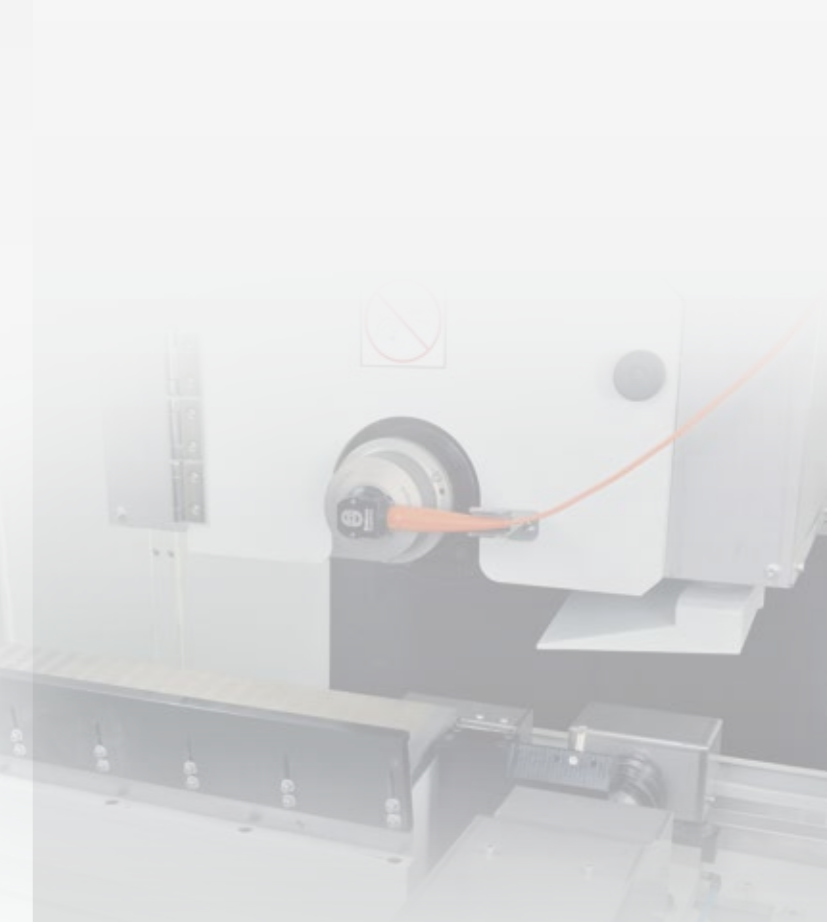



## ◀ Wheel Spindle

The high precision cartridge type spindle is supported by two precision angular contact ball bearings - at the front and rear ends. Bearings are preloaded and carefully assembled in a constant-temperature environment. Special grease for the NC machine spindle is employed without need of further lubrication and combined with non-contact labyrinth type seals, ensuring an excellent lubrication effect. Spacing collars are precision measured and preloaded before fitting. They are fixed at the front end and removable at the rear end. This allows thermal strain transfer to the rear end to minimize transmission error while assuring long service life and high accuracy.

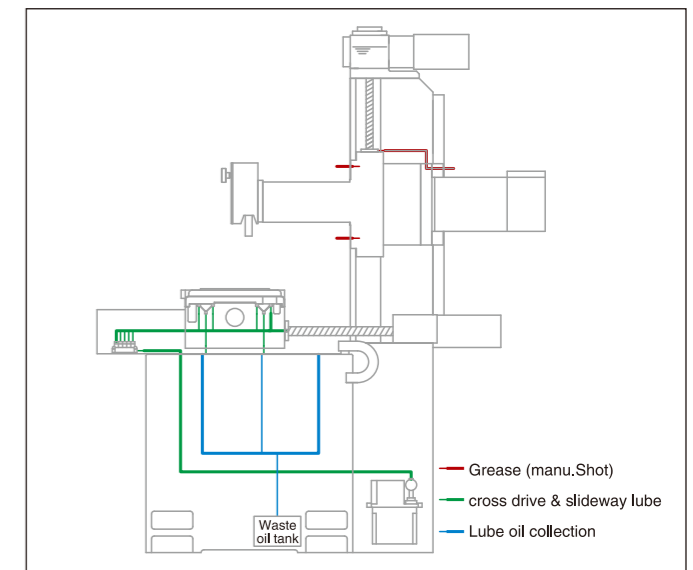
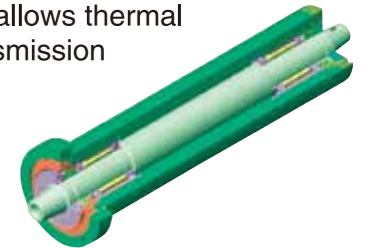

## ▲ Automatic Lubrication System

Each Joen Lih machine is equipped with an automatic lubrication system as standard equipment. The lubrication system employs an electromagnetic pump. Oil injection is controlled by PLC based on the moving distance set. Oil is delivered to all slideways, table, saddle, gears and screws for reducing friction, extending parts service life and ensuring machining accuracy. (In case of no oil, the lubricator will sound an alarm.)

## ▲ Longitudinal Table

The table travels on double V guideways, coated with low friction Turcite-B Precision scraping makes the table move smoothly on the guideway.

## ◀ One-Piece Fabricated Base

The massive base is one-piece constructed, providing a solid support for the saddle, table and column. This greatly upgrades stability and rigidity.

JL-63CNC-B



## FULLY ENCLOSED SPLASH GUARD

A powerful coolant flushing device is available. It provides cooling, lubrication, and chip exhaust functions for the workpiece, allowing the grinding wheel to maintain outstanding grinding quality at all times. In addition, it also dramatically reduces environmental pollution.



## Hydraulic Drive (H Series)



### Longitudinal Table

The table travels on double V guideways, coated with lowfriction Turcite-B Precision scraping makes the table move smoothly on the guideway. The longitudinal movement is driven by a hydraulic system, combined with flow control to provide variable speed change for the table.



### Right End Stop Function

The specially designed "Right End Stop" makes it easier for wheel auto dressing and auto compensation.



Precision hand-made scraping on guideway ensures extraordinary performance in surface grinding accuracies and finish where exceptional value for the investment is the goal. Test reports accompanying each grinder certify the built-in accuracies for these performance machine tools and attest to the meticulous hours of hand labor used in crafting to exacting specifications.



There is only one way to build a precision surface grinder. Hand scraping, then fitting, then hand scraping again and again until critical alignment parts fit exactly as designed without compromise.

## Ballscrew and Servomotor Drive (B Series)



### Superior Machining Efficiency

Joen Lih surface grinders employ precision ball screw and linear guide ways on the Y axis. AC servomotors directly drive the ball screw, combined with a sensitive servo system featuring high frequency response, making this machine ideal for continuous machining. This upgrades machine efficiency to a maximum.



### Precision Ballscrews

Ballscrews are specially hardened to reach 50HRC surface hardness. The leadscrews for vertical and cross feeds are precision ground to reduce backlash to a minimum. Thorough lubrication in the entire travel ensures high positioning and grinding accuracy.



### Linear Guideway

The linear guideway features in high-speed motion, high positioning accuracy, low friction and stability, making it ideal for high efficiency processing with linear motor. Linear guideways are mounted and fastened on the bed; thus, the issues of table floating and oil level difference are minimized even under high speed processing. The low-friction feature allows workpieces to have superior straightness accuracy after processing.

## Linear Motor (LM Series)

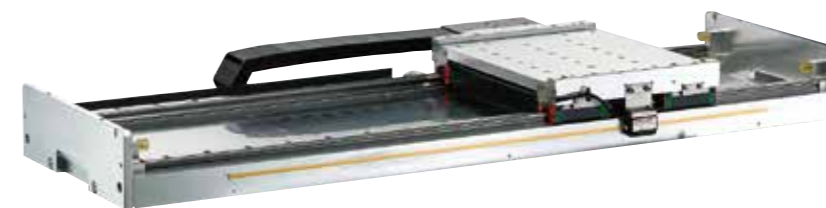

### Application

- P.C.B drilling machine
- Machine tool
- General Industrial machinery

### Features of Linear Motor

- Iron core design increases the efficiency of the linear motor.
- Due to less contact between mechanical parts, the linear motor features high response and long-term stability.
- Compared with ballscrew, the linear motor has higher moving speed and positioning accuracy, resulting from its high speed dynamic response and higher speed.



▲ JL-52CNC-LM



# ELECTRIC CONTROL SYSTEM

Controller systems are available for choose, including Fanuc, Siemens, and Syntec.

## CNC CONTROL

- 10.4" color LCD screen
- MMC 103 human-machine interface
- 19" machine control panel
- Program memory card
- Transmission interface
- MPG handwheel

## CNC STANDARD SPECIFICATIONS

- Controlled axes (X, Y, Z)
- Simultaneous controllable axes 2-4axes
- Least command increment 0.0001mm
- Inch/Metric conversion
- Emergency stop
- Servo off
- MDI operation
- Dry run
- Single block operation
- M.P.G. (Manual pulse generator)
- Linear Interpolation
- Circular Interpolation
- Dwell
- Skip function
- Manual reference point return
- Automatic reference point return
- 2nd reference point return
- Rapid positioning
- Automatic acceleration / deceleration
- Feed rate override 0-150% (10%per)
- Manual continuous feed
- Macro B
- Network socket
- M.P.G. interruption function
- EIA/ISO automatic recognition
- Self-diagnosis function
- X, Y, Z, B axes servo motor
- Wheel automatic dressing & compensation
- Dresser auto. Position
- Programmable control dresser
- Automatic tool diameter correction
- Backlash compensation
- Automatic coordinate system setting & conversion
- Part program storage length (649m)
- Spindle power display
- Custom macro
- Program protection
- Wheel speed protection
- Status display
- Lubrication alarm
- Program display protection
- Language display
- PMC-L ladder search
- Magnetic chuck voltage display
- Programmable control magnetic force
- Instruction display
- G codes menu display
- 10.4" TFT Colors display
- Programmable control

## Grinding Applications

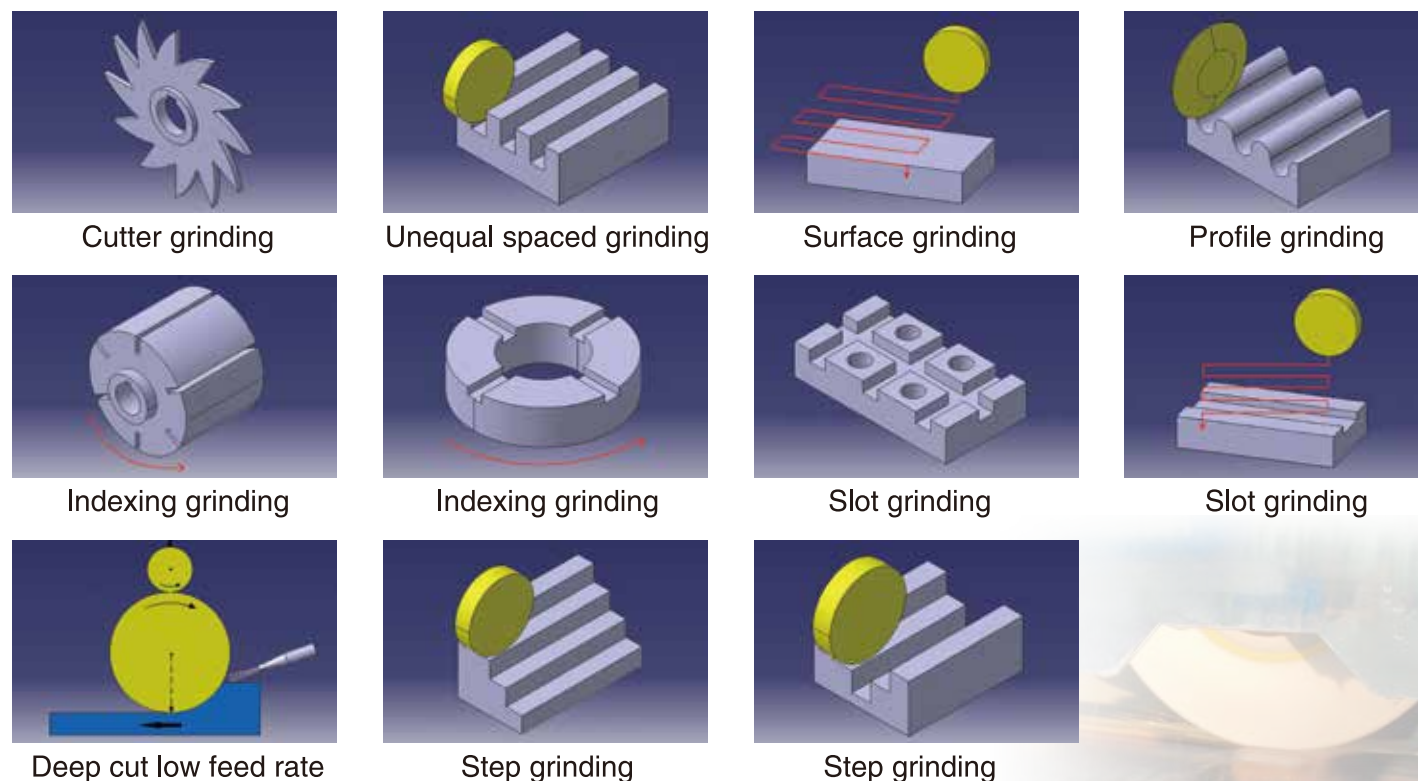

## Dressing Modes

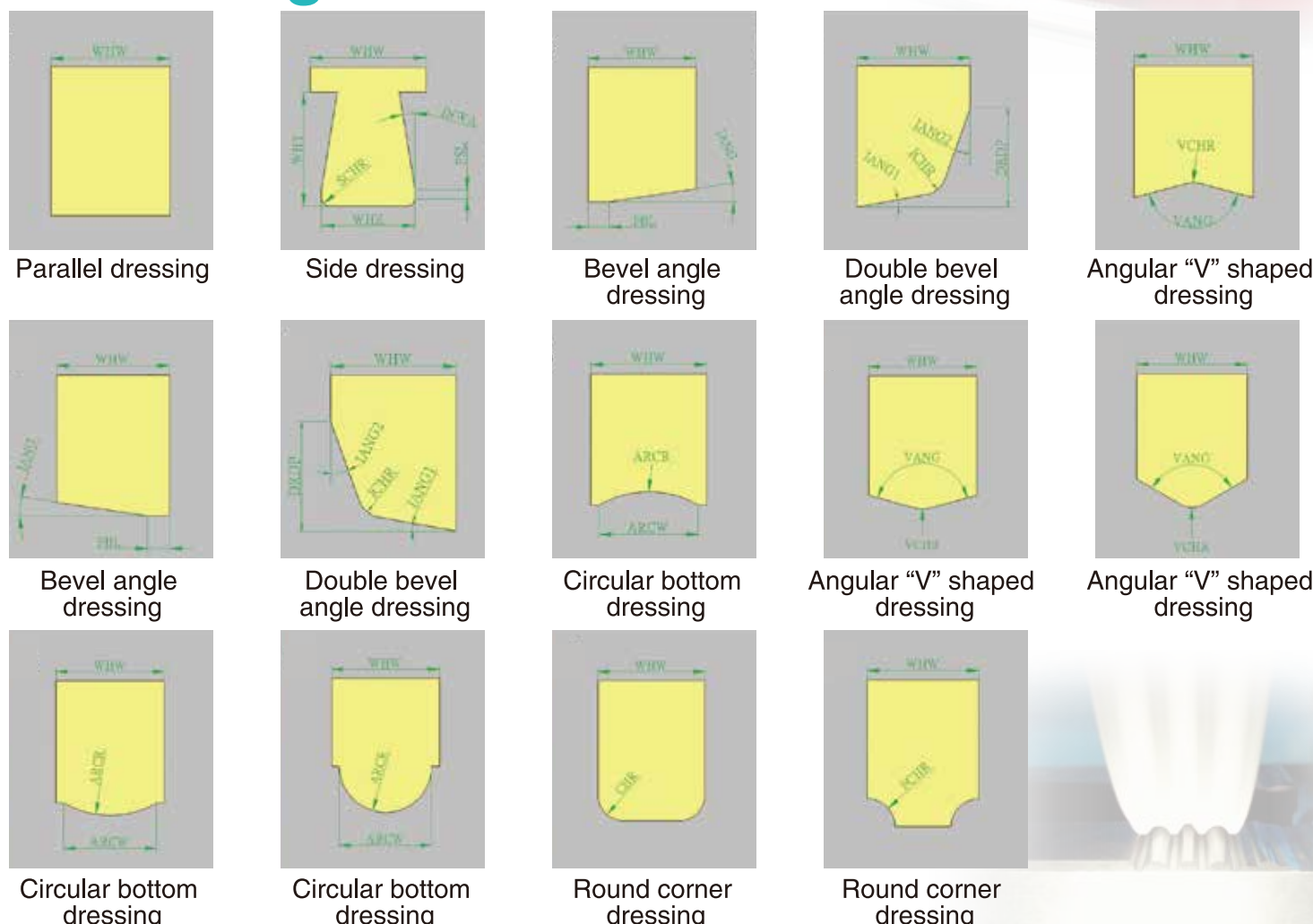

## Accessories



### STANDARD ACCESSORIES

- Grinding wheel
- Wheel flange
- Flange extractor
- Wheel balancing arbor
- Levelling screws
- Levelling pads
- Tool box and tools
- Working lamp
- Totally enclosed splash guard

### OPTIONAL ACCESSORIES

- Electro magnetic chuck
- Inclinal electro magnetic chuck
- Table mounted dresser
- Angle Dressing attachment
- Coolant system
- Precision vise
- Coolant system with magnetic separator
- Coolant system with paper filter
- Table mounted single diamond disc (Diamond disc is not included)
- Table mounted double diamond disc (Diamond disc is not included)
- Coolant system with paper strip filter and magnetic separator
- Oil mist collector
- Demagnetizer
- Wheel parallel dresser
- Coolant system
- Angle dressing device
- Combination coolant and dust exhaust unit
- Radius dressing device
- Punch former
- Sine bar
- Digital scale
- Hydraulic freezer

# MACHINE SPECIFICATIONS

MODEL	UNIT	JL-52CNC-H	JL-52CNC-B	JL-52CNC-LM	JL-2550CNC-H	JL-2550CNC-B	JL-63CNC-H	JL-63CNC-B	JL-4080CNC-H	JL-4080CNC-B	JL-4080CNC-340	JL-4080CNC-341 (LONG. GRINDING)	JL-4080CNC-344 (HEAVY CUT / DEEP CUT LOW FEEDRATE)
<b>GENERAL CAPACITY</b>													
Table size	mm	200 x 400	200 x 400	200 x 300	250 x 500	250 x 500	300 x 600	300 x 600	400 x 800	400 x 800	400 x 800	400 x 800	400 x 800
Maximum stroke	mm	230 x 560	220 x 585	230 x 360	290 x 550	290 x 550	350 x 700	350 x 700	460 x 960	460 x 960	480 x 1100	430 x 1100	480 x 1100
Surface of magnetic chuck (W x L)	mm	200 x 400	200 x 400	200 x 300	250 x 500	250 x 500	300 x 600	300 x 600	400 x 800	400 x 800	400 x 800	400 x 800	400 x 800
Max. distance from spindle center to table	mm	400	400	365	470	470	600	600	650	650	600	650	600
Max. table load (incl. mag. chuck)	kgs	250	250	250	250	250	300	300	500	500	800	800	800
<b>WHEEL SPINDLE</b>													
Max. spindle speed	rpm	3600 (60Hz) 2900 (50Hz)	3600	10000	3600 (60Hz) 2900 (50Hz)	3600 (60Hz) 2900 (50Hz)	1750 (60Hz) 1450 (50Hz)	1750 1450	1750 1450	1750 1450	0~8000	0~8000	0~3000
Spindle motor	Kw	Ind. motor 1.5 x 2P	Ind. motor 1.5 x 2P	Ind. motor 3 x 2P	Ind. motor 2.25 / 3.75	Servomotor 9	Servomotor 5.5	Servomotor 11.2	Ind. motor 3.75 (Opt. 5.25)	Ind. motor 5.25	Servomotor 18 / 16	Servomotor 11	Servomotor 28 / 39
Grinding wheel (O.D. x W x I.D.)	mm	ø180 x 13 x ø31.75	ø180 x 13 x ø31.75	ø180 x 13 x ø31.75 ø75 x6 x ø31.75	180 x 13 x 31.75 (255 x 19 x 50.8)	255 x 19 x 50.8	355 x 50 x 127	355 x 50 x 127	355 x 38 x 127 405 x 50 x 127	405 x 50 x 127	ø355 x 50 x ø127	ø355 x 50 x ø127	ø510 x 50~150 x ø203.2
<b>X-AXIS LONGITUDINAL MOVEMENT</b>													
Stroke	mm	560	585	300	550	550	700	700	960	960	1100	Z-axis: 430	1100
Drive method		Hydraulic	Ballscrew	Linear motor	Hydraulic	Ballscrew	Hydraulic	Ballscrew	Hydraulic	Ballscrew	Ballscrew	Ballscrew	Ballscrew
Hydraulic / Servo motor	Kw	-	Servomotor 1.3	Linear motor 10.5	Hyd. motor 0.75	Servomotor 1	Hyd. motor 1.5	Servomotor 2	Hyd. motor 2.2	Servomotor 2	Servomotor 4.5 (4.1)	Servomotor 4	Servomotor 5
Table speed	m/min	3~25	3~20	1~36	0~25	0~25	3~23	0~30	0-25	3-25	0-20	10	0-25
Guideway		Double V guideway	Double V guideway	Double V guideway / Linear guideway (opt.)	Double V guideway	Double V guideway	Double V guideway	Double V guideway	Double V guideway	Double V guideway	Linear guideway	Linear guideway	Linear guideway
<b>Y-AXIS VERTICAL MOVEMENT</b>													
Stroke	mm	285	285	285	340 / 380	340	430	430	470 / 445	445	420	470	345
Ballscrew (dia.)	mm	Ø25	Ø25	Ø25	-	-	-	-	Ø50	Ø50	Ø50	Ø50	Ø50
Servomotor	Kw	0.4	0.75	0.4	0.75	1.4	2	2	1	1	5	4	5
Infeed rate	mm/min	300	300	300	500	500	16000	16000	500	500	10	10	3
The least input increment	mm	0.001	0.001	0.001	0.001	0.001	0.001	0.001	0.001	0.001	0.001	0.001	0.001
Guideway		Hard rail	Hard rail	Hard rail	Linear Guideway	Linear guideway	Linear guideway	Linear guideway	Linear guideway	Linear guideway	Linear guideway	Linear guideway	Linear guideway
<b>Z-AXIS CROSS MOVEMENT</b>													
Stroke	mm	230	220	230	290	290	350	350	480	480	480	X-axis: 1100	480
Ballscrew (dia.)	mm	Ø25	Ø25	Ø25	-	-	Ø50	Ø50	Ø50	Ø50	Ø50	Ø50	-
Servomotor	Kw	0.4	0.4	0.4	0.75	1.4	1	1	1	1	3.0 (2.7)	Servomotor 4	Servomotor 5
Infeed rate	m/min	1200	1200	1200	300	3000	15000	15000	500	500	10	20	5
The least input increment	mm	0.001	0.001	0.001	0.001	0.001	0.001	0.001	0.001	0.001	0.001	0.001	0.001
Guideway		Double V guideway	Double V guideway	Double V guideway	Double V guideway	Double V guideway	Double V guideway	Double V guideway	Double V guideway	Double V guideway	Linear guideway	Linear guideway	Linear guideway
<b>WHEEL DRESSER</b>													
Diamond roller (O.D. x W x I.D.)	mm	Diamond tool (Opt.)	Diamond tool (Opt.)	Diamond tool (Opt.)	Diamond tool (Opt.)	ø100 x max.50 x ø52	Diamond tool (Opt.)	ø100 x max.50 x ø52	Diamond tool (Opt.)	ø100 x max.50 x ø52	ø100 x max.20 x ø52	ø100 x max.20 x ø52	ø130 x max.160 x ø52
Max. rotating speed	rpm	-	-	-	-	2000	-	-	-	-	5000	5000	6000
Servomotor	Kw	-	-	-	-	0.5	-	-	-	-	0.5	0.5	3
<b>WEIGHT</b>													
Machine weight	Kgs	1450	1500	1450	1800	1800	2800	3200	4200	4200	8000	9000	6000
<b>SPACE</b>													
Machine working space	mm	1900 x 2100	1900 x 2100	1900 x 2010	2760 x 1800	2760 x 1800	3320 x 3160	2730 x 2750	5150 x 4400	5150 x 4400	3490 x 3260 x 2355	3490 x 3150 0 2830	3490 x 3260 x 2355
Packing dimensions (L x W x H)	mm	2880 x 2300 x 2250	2810 x 2200 x 2230	2810 x 2200 x 2230	2400 x 2280 x 2200	2400 x 2280 x 2200	3150 x 2100 x 2360	3150 x 2250 x 2360	3600 x 2450 x 2450	-	3700 x 2780 x 2550	3700 x 2780 x 3050	3700 x 2780 x 3050

\*Machine specifications and design characteristics are subject to change without prior notice.